

ACQ2106 Installation Guide



High Performance Simultaneous Data Acquisition

ACQ2106 6-Site D-TACQ ELF Carrier with High-Speed Comms

© D-TACQ Solutions Ltd.

The material contained in this document is provided "as is", and is subject to being changed, without notice, in future editions. Further, to the maximum extent permitted by applicable law, D-TACQ disclaims all warranties, either express or implied, with regard to this manual and any information contained herein, including but not limited to the implied warranties of merchantability and fitness for a particular purpose.

D-TACQ shall not be liable for errors or for incidental or consequential damages in connection with the furnishing, use, or performance of this document or of any information contained herein.

Should D-TACQ and the user have a separate written agreement with warranty terms covering the material in this document that conflict with these terms, the warranty terms in the separate agreement shall control.

Table Of Contents

1 Overview	3
1.1 Product Description	3
1.2 Variations and Options	3
1.3 Glossary	3
2 Front Panel	4
2.1 ACQ2106 Type 1	4
2.2 ACQ2106 Type 2	4
2.3 D-TACQ ELF Sites	4
2.4 LEDs	4
3 Front Panel Features	5
3.1 Clock [CLK]	5
3.2 Trigger [TRG]	5
3.3 Auxilliary Connectors[AUX1 AUX2]	5
3.4 TTL or Opto-Coupled Signals	5
3.5 Air Inlets	6
4 Rear Panel	7
5 Rear Panel Features	7
5.1 Power and Chassis Stud	7
5.2 Console [CONSOLE]	7
5.3 Ethernet [ETH]	7
5.4 Reset [RESET]	7
5.5 Sync Bus [SYNC OUT] [SYNC IN]	7
5.6 High-speed Comms	8
5.7 Fans	8
6 D-TACQ ELF Module Replacement	9
6.1 Case Opening	9
6.2 Mezzanine Module Removal	9
6.3 Card replacement and Case Closing	10
6.4 Card replacement Detail VHDCI Connector	10
7 Specifications	11
7.1 Electrical and Environmental	11
7.2 Declaration of Conformity and Test Certificates	11
7.3 Warranty	11
8 Mounting Options	12
9 Dimensions	13
10 Changelog	14

1 Overview

1.1 Product Description

The ACQ2106 is a 1U (2U option), 19" rack-mountable carrier designed to accommodate up to six D-TACQ ELF modules, allowing up to 192 simultaneous analog data acquisition channels in one enclosure. ACQ2106 provides multiple high-speed comms links for high data throughput as well as Gigabit Ethernet or USB 2.0 options. The system uses a Xilinx Zynq-7000 All Programmable SoC Z-7030 running Linux. External front panel Clock and Trigger inputs are also provided.

1.2 Variations and Options

ACQ2106 can be configured for multiple high-speed comms options. For other options including USB and local storage please contact support@d-tacq.com.

The ACQ2106 provides on-board Analog Power for D-TACQ ELF modules which are configured to suit the Module payload, contact support@d-tacq.com for details.

1.3 Glossary

- FMC : VITA57.1 FPGA Mezzanine Card
- ELF : Electrically Extended FMC, implies ULPC or DULPC (only compatible with D-TACQ carriers)
- LPC : FMC Low Pin Count standard as per VITA57.1
- ULPC : Subset by D-TACQ, Ultra Low Pin Count
- DULPC : Subset by D-TACQ, Differential Ultra Low Pin Count (ULPC with extra differential signalling)
- Xilinx ZYNQ System on Chip (SoC)
- FPGA : Field Programmable Gate Array
- WR : White Rabbit Timing System for precise Network Timing

2 Front Panel

2.1 ACQ2106 Type 1

This is the original ACQ2106 Front Panel manufactured until early 2020. The Front Panel appearance is shown below

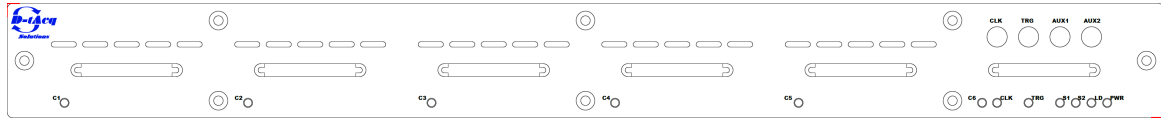

Figure 1: Type 1 ACQ2106 Front Panel

All ACQ2206 Front Panel options are supported. Contact support@d-tacq.com for details including custom panels.

2.2 ACQ2106 Type 2

This is the updated ACQ2106 Front Panel manufactured from early 2020. The Front Panel appearance is shown below, for 6 VHDCI cut outs.

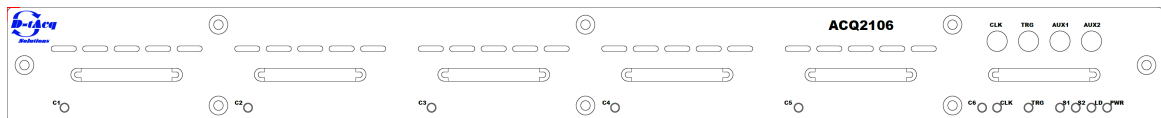

Figure 2: Type 2 ACQ2106 Front Panel

2.3 D-TACQ ELF Sites

ACQ2106 has space for six D-TACQ ELF modules. Please note the sites are not recommended for third-party FMC modules. Please contact support@d-tacq.com for details on our range of data acquisition modules, see Section 6.4 for details on field replacement.

2.4 LEDs

Upon power-up, the PWR LED should light, followed 20s later by LD to indicate loading of the FPGA. When Linux boots, an LED test sequence will be shown, showing red and green on each LED.

LED	Description	
C1-C6	Green	Card present, valid configuration. Analog power enabled if all cards are valid.
	Red	Card present, invalid configuration. Analog Power disabled if any card is invalid.
CLK	Green	Lit when a valid clock signal is in use <i>Overridden in a WR system to indicate valid PPS</i>
	Red	Unused at present.
TRIG	Green	Lit when a valid trigger signal is being received.
	Red	Unused at present.
S1	Green	Unused at present. Available for user use.
	Red	Unused at present. Available for user use.
S2	Green	Heartbeat – flashes to indicate Linux activity.
LD	Green	Lights approximately 20s after power-up to indicate FPGA loaded. If unlit after this, check the validity of the SD card image or check the Console for error messages.
PWR	Green	Lit when digital power supplies are all valid.

Table 1: Front Panel LEDs

3 Front Panel Features

3.1 Clock [CLK]

The ACQ2106 accepts a clock input signal via a centre-positive single-pin LEMO 00 Series Mini Coax connector (part EPL.00.250.NTN). Mating plugs should be compatible with this part.

3.2 Trigger [TRG]

The ACQ2106 accepts a trigger input signal via a centre-positive single-pin LEMO 00 Series Mini Coax connector (part EPL.00.250.NTN). Mating plugs should be compatible with this part.

3.3 Auxilliary Connectors[AUX1 AUX2]

These are two I/O signals, input only when configured as Opto-Coupled. These signals can be used to provide additional synchronisation inputs or can be used to output signals from the ACQ2106, for example Clock and or Trigger. Further details can be found in the user guide at [D-TACQ Resource / User Guides](#).

3.4 TTL or Opto-Coupled Signals

All Front Panel LEMO input signals can be configured as either 5V TTL inputs or Opto-Coupled inputs. The Opto-Coupled inputs are of type TLP2367. See Table 4 below for the Opto-Coupler characteristics; if higher input voltages are required a user in-line resistor may be used to reduce the input voltage at the connector. Contact support@d-tacq.com to verify any setup.

The factory shipping settings on the Top Deck Switches are as follows

Signal	Default Setting
Clock	Opto-Coupled Input
Trigger	Opto-Coupled Input
AUX1	TTL Input/Output
AUX2	TTL Input/Output

Table 2: Front Panel I/O Default Switch Positions

When configured as TTL inputs or outputs the signals have the following electrical specification. Note Clock and Trigger are input only

Parameter	Value
TTL Input Low Voltage	< 1.5V ¹
TTL Input High Voltage	> 3.5V ¹
Minimum Input Voltage	-0.5V ²
Maximum Input Voltage	5.5V ²
TTL Output Low Voltage	< 0.55V ³
TTL Output High Voltage	> 3.8V ³
TTL Max Output Current	24 mA

¹ Trigger Input has a guaranteed hysteresis of 700mV

² Inputs have under/over voltage protection up to 100mA

³ Output Voltages at specified Max Current

Table 3: TTL Input and Output Characteristics

When configured as Opto-Coupled inputs the signals have the following electrical specification

Parameter	Value
Input Low Voltage	< 0.6V
Input High Voltage	> 4V
Minimum Input Voltage	-5V
Maximum Input Voltage	9V
Min ON LED Current	4 mA
Max LED Current	15 mA

Table 4: Opto-Coupled Input Characteristics

Each signal is independently selected for TTL or Opto-coupled using individual switches on the FP Top-Deck. This board is accessed by removing the top cover of the ACQ2106 and is located immediately behind the Front Panel LEMO connector.

Selecting the signalling type for each signal requires two switches to be set as follows

Setting	SWAn	SWBn
Opto-Coupled Input	B	B
Bypass/TTL Input/Output	A	A

Table 5: Front Panel TTL / Opto Switch Positions

The Top Deck Switches are shown in the picture below

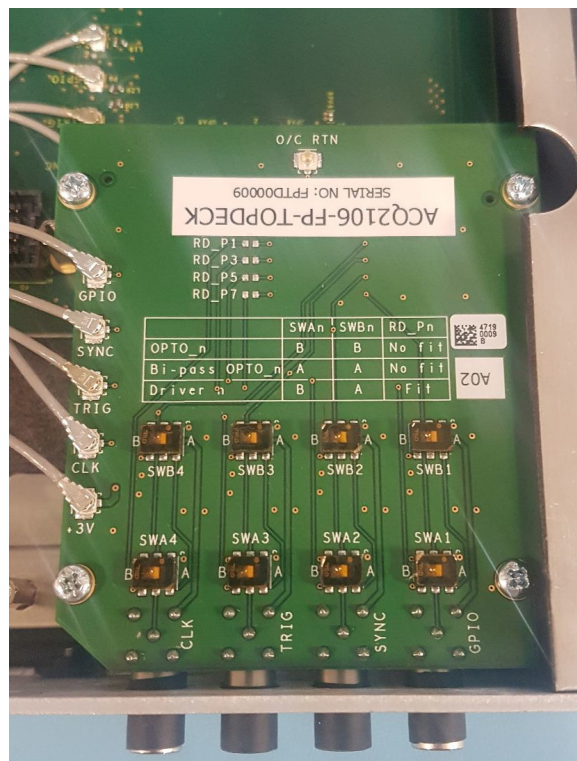

Figure 3: Top Deck Switches

3.5 Air Inlets

The row of slots above the module front panel sites allow air to enter ACQ2106, drawn across the cards by the rear fans. Do not cover the air inlets.

4 Rear Panel

The ACQ2106 rear panel is shown below.

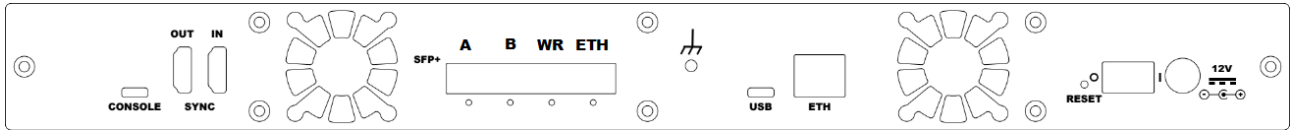

Figure 4: Rear Panel

5 Rear Panel Features

5.1 Power and Chassis Stud

Power is provided to ACQ2106 by an external 12V regulated DC supply capable of outputting approximately 80W, although a supply capable of a minimum of 30W may be used depending on payload. A rocker switch allows ACQ2106 to be powered on or off. The socket accepts a standard DC barrel connector, centre-positive, 2.5mm internal diameter, 5.5mm external diameter, with length a minimum of 10.5mm. The power supply's input Earth should be connected to the output 0V.

The ACQ2106 must be powered from the D-TACQ supplied Power Supply.

5.2 Console [CONSOLE]

ACQ2106 uses an FTDI FT232R USB-Serial converter for console access via a Micro USB port. Please see the FTDI website for drivers. Serial Console settings are as follows.

Name	Setting
Baud Rate	115200
Data Bits	8
Parity	No
Stop Bits	1
Flow Control	None

Table 6: Serial Console Settings

5.3 Ethernet [ETH]

A single Gigabit Ethernet port is provided that accepts standard RJ45 connectors.

5.4 Reset [RESET]

The Reset push button is recessed. Use a paper clip or pin to push the reset button if required.

5.5 Sync Bus [SYNC OUT] [SYNC IN]

ACQ2106 provides 2 Sync Bus connectors allowing multiple units to be chained together. The bus uses standard HDMI cables (typically provided by the customer) and has one input port and one output port. These are labelled SYNC IN and SYNC OUT.

The Sync Bus uses +3.3V CMOS logic and is compatible with other D-TACQ carriers. Breakout modules (TERM05, TERM10, TERM11; see [Termination Modules](#)) providing various connector and signal options are also available.

The sync ports may also be used for digital I/O in some customer applications. Please contact support@d-tacq.com for details.

Please note the system is not capable of video output - do not connect to a monitor – the ports may only be used for digital I/O.

The pinouts and functionality are described as follows.

Pin	Name	Description	
		Output Connector	Input Connector
1	Sync	Synchronisation Output	Synchronisation Input
4	Trigger	Trigger Output	Trigger Input
7	GPIO	General Purpose Output	General Purpose Input
10	CLK	Clock Output	Clock Input
19	Cable Detect	Allows master to detect the presence of a slave device.	Ground (0VD)
18	+3.3V	+3.3V input from slave to power output signals	+3.3V output to master to power output signals
13,14,15,16	NC	Not connected	
2,3,5,6,8,9,11,12,17	GND	Ground (0VD)	

Table 7: HDMI Connector Pin Out

5.6 High-speed Comms

ACQ2106 is capable of providing multiple high-speed comms options. This is provided by an optional auxiliary module that is connected to the Main ACQ2106 PCB inside the enclosure. The available modules are summarised below, contact support@d-tacq.com for more details.

- MGT482 - Up to four SFP+ Fiber ports. Standard Configuration is
 - 2 x Xilinx Aurora Ports for connection to a Host Computer with D-TACQ [AFHBA404](#). Uses Ports A & B by default.
 - 1 x White Rabbit Gigabit Ethernet Port. Uses Port C by default.
 - 1 x Fibre Gigabit Ethernet 1000Base-X or HUDP (Hardware UDP) Gigabit Ethernet Port. Uses Port D by default.
- MGTDRAM - Intelligent board with onboard memory expansion of up to 8 GBytes

5.7 Fans

Fan outlets help keep ACQ2106 cool, drawing air across the modules from front to back. Do not cover the fan outlets.

Airflow may be reversed as a factory option.

6 D-TACQ ELF Module Replacement

The ELF modules may be replaced by the user. Contact support@d-tacq.com for more detailed instructions.

⚠ WARNING

The system should be disconnected from the mains supply and ESD precautions taken before attempting to open the ACQ2106 Assembly.

VITA 57 LPC FMC modules cannot be used with the ACQ2106. Please consider using D-TACQ FMC carriers which are all fully compliant with the FMC standard for VITA-57 FMC-LPC modules

ACQ2106 is a complex electronic assembly. Special care should be taken in handling. The cards are susceptible to damage by ESD and improper power connections or FPGA configurations.

1. Ensure the correct FPGA image is available for the new module configuration.
2. Ensure the system is disconnected from the mains.
3. Ensure ESD precautions (chassis and body grounding) are taken before and during the opening of the case.
4. Please be extremely careful to ensure correct module alignment when plugging in the modules to avoid mezzanine module pin damage.

6.1 Case Opening

1. Remove the 6 screws on the top panel.
2. Remove the 3 screws at the top of each of the front and rear panels.
3. Lift the lid off.

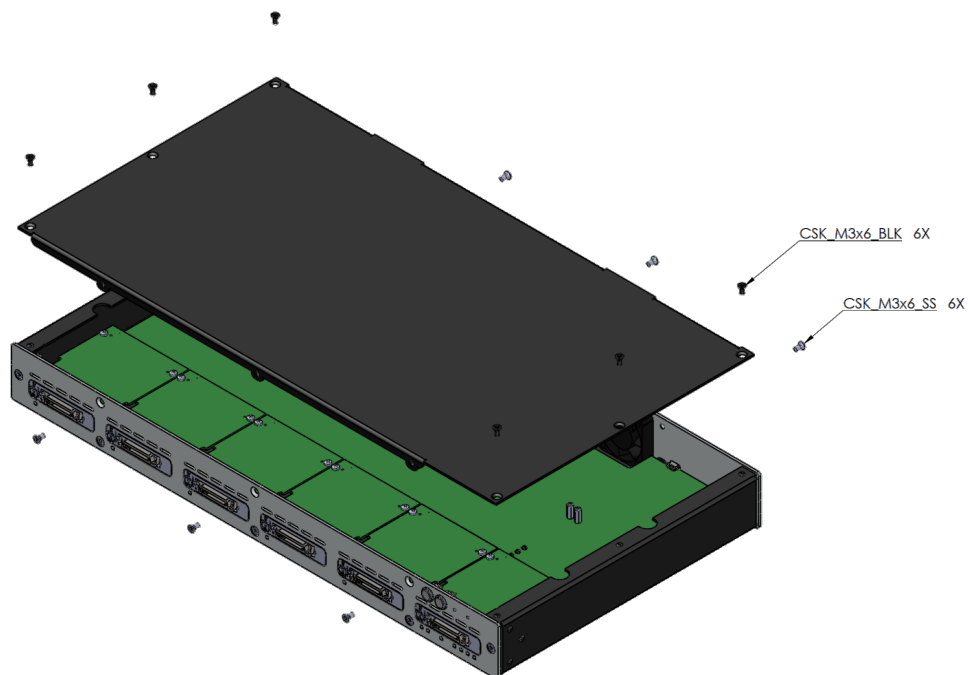

Figure 5: ACQ2106 Top Cover Removal

6.2 Mezzanine Module Removal

1. Remove the 2 screws at the front.

2. Remove the 4 screws at the front and rear of the module. Remove the 2 screws in the centre of D-TACQ Extended Length modules.
3. Carefully lift the card away from the mezzanine connector. Note that not a lot of force is required to do this and the module should not bend.
4. Jog the module out from the front panel.

6.3 Card replacement and Case Closing

1. Follow the above instructions in reverse order.
2. Ensure the correct FPGA and Software images are installed prior to powering up.

6.4 Card replacement Detail VHDCI Connector

When fitting a new module with a VHDCI connector an adhesive backed VHDCI SHIM (part number: 1350-1093-001) is required as shown in the diagram below

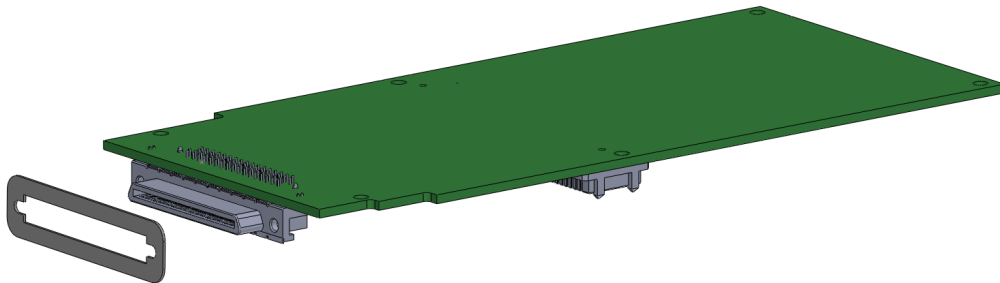

Figure 6: VHDCI Shim on ELF Module

Use the screw locks and secure the module to the Front Panel to give the final assembly shown below

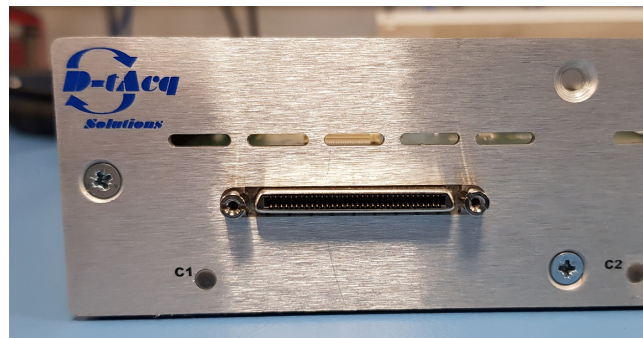

Figure 7: VHDCI Screwlocks

7 Specifications

7.1 Electrical and Environmental

Parameter	Description
Form Factor	Standard 1U 19" Chassis ¹
Power Source	Standard 12V DC power inlet 2.5mm Int Diameter, 5.5mm Ext diameter
Power Consumption	Dependent on payload but typically 15-25W + 10W per site. Maximum 84W
Environmental	0°C - 50°C Operational -10°C - 85°C Non-Operational
Case Dimensions Standard	Width 441 mm x 236 mm Depth x 1U High
Case Dimensions Channel Panel	Width 441 mm x 256 mm Depth x 1U High

¹ 2U Configurations available for additional connector options

Table 8: ACQ2106 Specifications

7.2 Declaration of Conformity and Test Certificates

The ACQ2106 complies with International safety and EMC requirements.

Declarations of Conformity and Test Certificates for this product and for other D-TACQ products can be found on the website:

Declarations of Conformity

[ACQ400 EC Declaration of Conformity](#)

[ACQ400 FCC Declaration of Conformity](#)

Test Certificates

[ACQ2106 EN EMI Test Certificate](#)

[ACQ2106 FCC EMI Test Certificate](#)

See the [Product Certification](#) page

7.3 Warranty

© D-TACQ Solutions Ltd.

The material contained in this document is provided "as is", and is subject to being changed, without notice, in future editions. Further, to the maximum extent permitted by applicable law, D-TACQ disclaims all warranties, either express or implied, with regard to this manual and any information contained herein, including but not limited to the implied warranties of merchantability and fitness for a particular purpose.

D-TACQ shall not be liable for errors or for incidental or consequential damages in connection with the furnishing, use, or performance of this document or of any information contained herein.

Should D-TACQ and the user have a separate written agreement with warranty terms covering the material in this document that conflict with these terms, the warranty terms in the separate agreement shall control. This equipment is not suitable for use in locations where children are likely to be present.

8 Mounting Options

ACQ2106 mounts in a 19" rack. Alternatively, the custom-built case allows stand-alone use with optional tilting feet. Please contact support@d-tacq.com for options.

Mounting of the 19" Rack Mount lugs are shown in the diagrams below, these are on on both the left and right of the case.

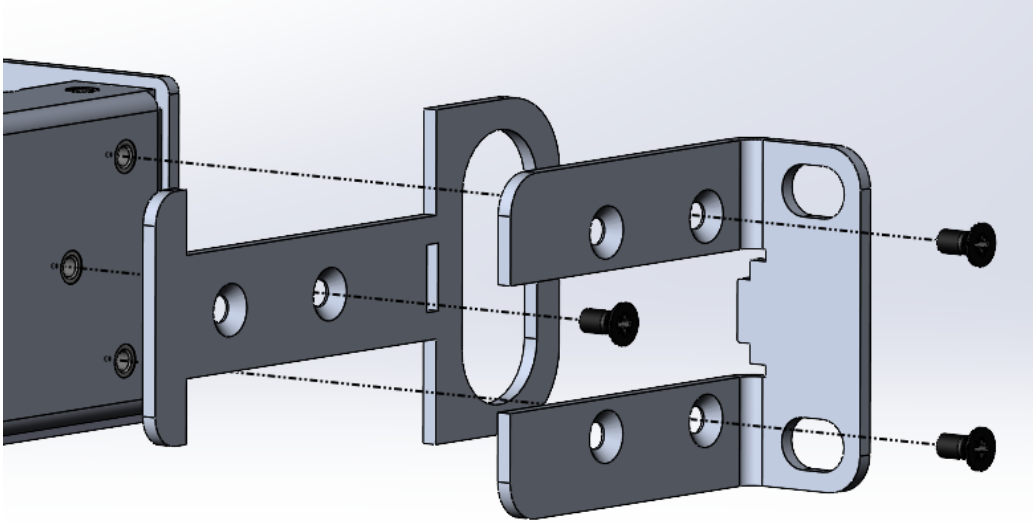

Figure 8: Standard Case Rack Mount

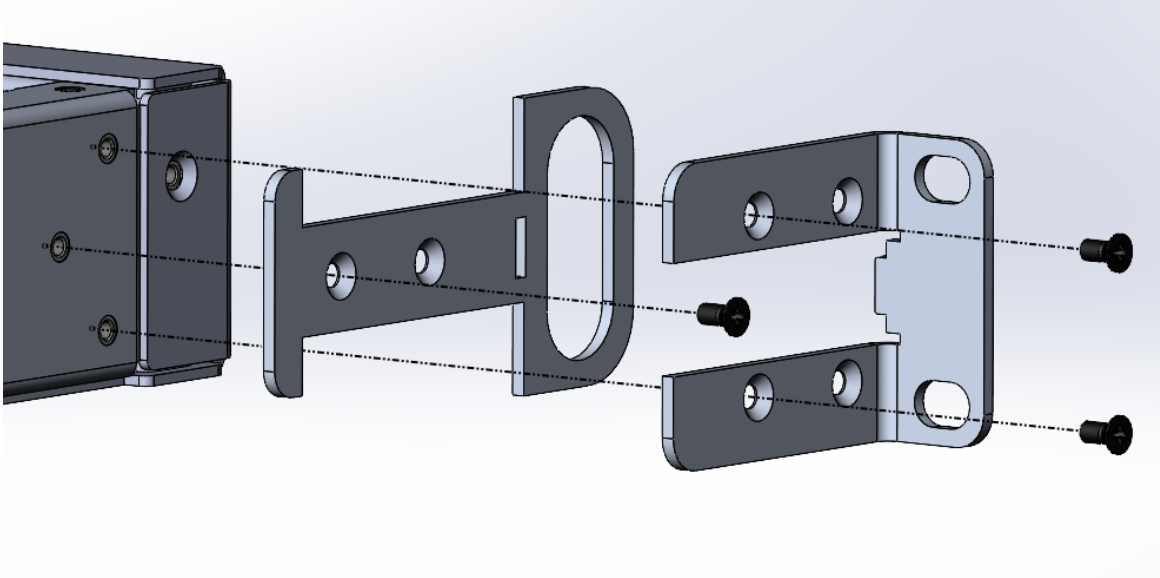

Figure 9: Channel Panel Case Rack Mount

9 Dimensions

The dimensions of the Standard case and the Channel Panel case are shown below

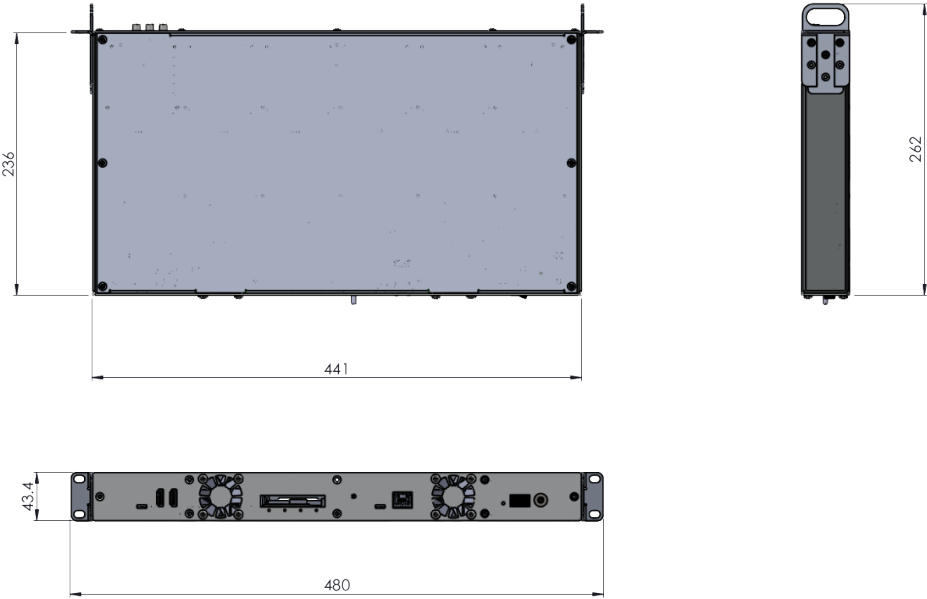

Figure 10: ACQ2106 Standard Case Dimensions (mm)

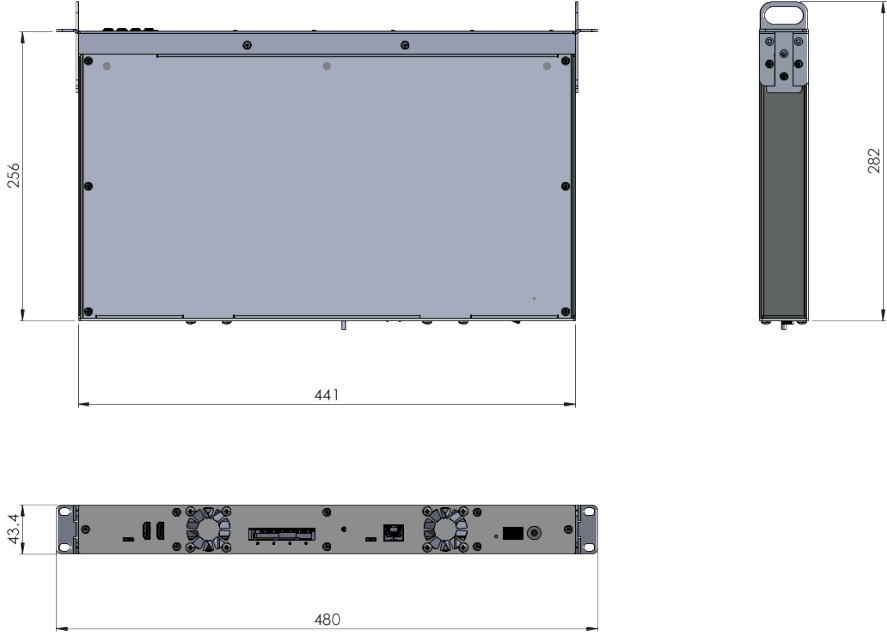

Figure 11: ACQ2106 Channel Panel Case Dimensions (mm)

10 Changelog

Revision History

Revision	Date	Author(s)	Description
1	3/2015	PJ	Initial Release
2	5/2020	JMcL	Update to Rev 2 Front Panel
3	7/2015	JMcL	Rack Mounting detail
4	10/2020	BK	Module replacement
5	6/2023	JMcL	Type 2 Rear Panel Detail, DOC and Warranty
6	24/7/2023	JMcL	Updated D-TACQ Format
7	August 2023	JMcL	Include Channel Panel Dimensions
8	October 2023	JMcL	Added Top Cover Removal Diagram
9	February 2025	JMcL	Added Declaration of Conformity and Test Certificates